

Print Number:

Print Date:

NOBLELIFT



Scan QR Code for More

Electric Tow Tractor TE10Li

PARTS MANUAL

565446020101

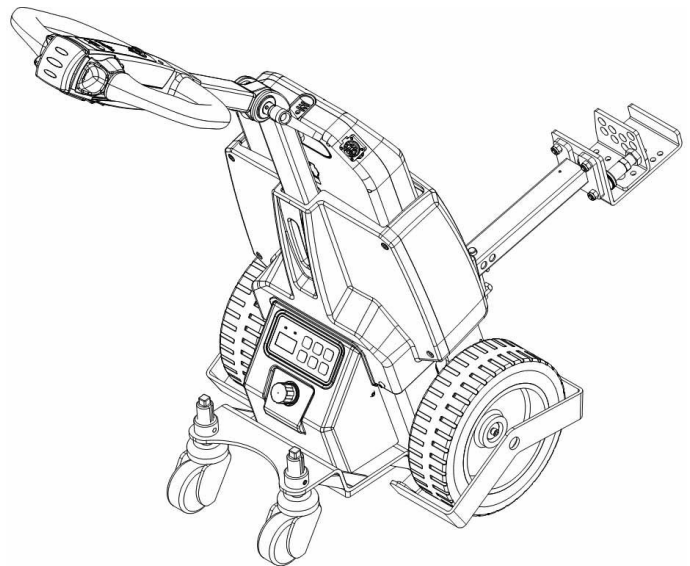

Version V02

Truck Identification Number From:

Parts Manual TE10Li-PM02EN

Please order parts from authorized dealers of Noblelift Intelligent Equipment Co., LTD.

In order to avoid wrong delivery, all the orders for spare parts should specify the following items:

- Truck model, identification number and manufacture year.
- Orders for spare parts of mast, hydraulic transmission unit, steering axle, motor, etc. shall indicate the manufacture number of these parts.
- Codes for Noblelift spare parts are shown in the table of parts manual. Please also pay attention to the description of supply status, order quantity, etc. (check the number listed in "Mark" column of the parts manual).

"Mark" Column:

The unmarked indicates the parts are in short supply cycle.

Number 1: supply as package. Indicating these that parts are small parts and seal parts, which are supplied in package unit and in short supply cycle.

Number 2: supply with constraints. Indicating that these spare parts are not in stock and will be prepared for production after receiving the order from customers, which are in long supply cycle.

Number 3: phasing-out supply. Indicating that these parts will be replaced by new parts due to technical improvements and the current stock will not be available when these parts run out. Please check the description of technical improvements notice.

Number 4: supply as assembly. Indicating that these parts are assembly parts defined by manufacture process, which cannot be supplied as a single part.

Number 5: check other tables.

This parts manual is the property of Noblelift and can be shared under the confidential agreement only, Noblelift has the right to claim for compensation of any unauthorized use. Copy without permission is not allowed. Figures in the manual are not limited by the original design. Noblelift Intelligent Equipment Co., LTD reserves the right to improve the products for continuous technology progress.

Table of Contents

Chapter 1: Drive System.....	4
01 Drive Assembly (565446013501).....	4
02 Drive Unit (565346013502).....	6
Chapter 2: Truck Frame	8
01 Traction Frame Unit (565446038001)	8
02 Traction Frame (S) (565446038002).....	10
03 Traction Frame (P) (565446038003).....	12
04 Traction Frame (LKE) (565446038005).....	14
05 Chassis (565446021501).....	16
05 Chassis (565446021501) Continuation.....	18
Chapter 3: Steering System, Braking System, Wheels	20
01 Tiller Unit (565446011001)	20
02 Control Handle (565446011002)	22
Chapter 4: Electrical Parts	24
01 Wire Harness (565446033001)	24
02 Electronic Components (565446033002)	26
03 Display Assembly (565446010001).....	28
04 Charger (508046036501).....	30
04 Charger (508046036501) Continuation	32
05 Traction Battery (565446037001).....	34
Chapter 5: Others	36
01 Label and Decal (565446047001).....	36
02 Label and Decal (USA) (565446047004).....	38
Appendix.....	40
01 Electrical Circuit Diagram	40
02 Consumable Parts List	41

Chapter 1: Drive System

01 Drive Assembly (565446013501)

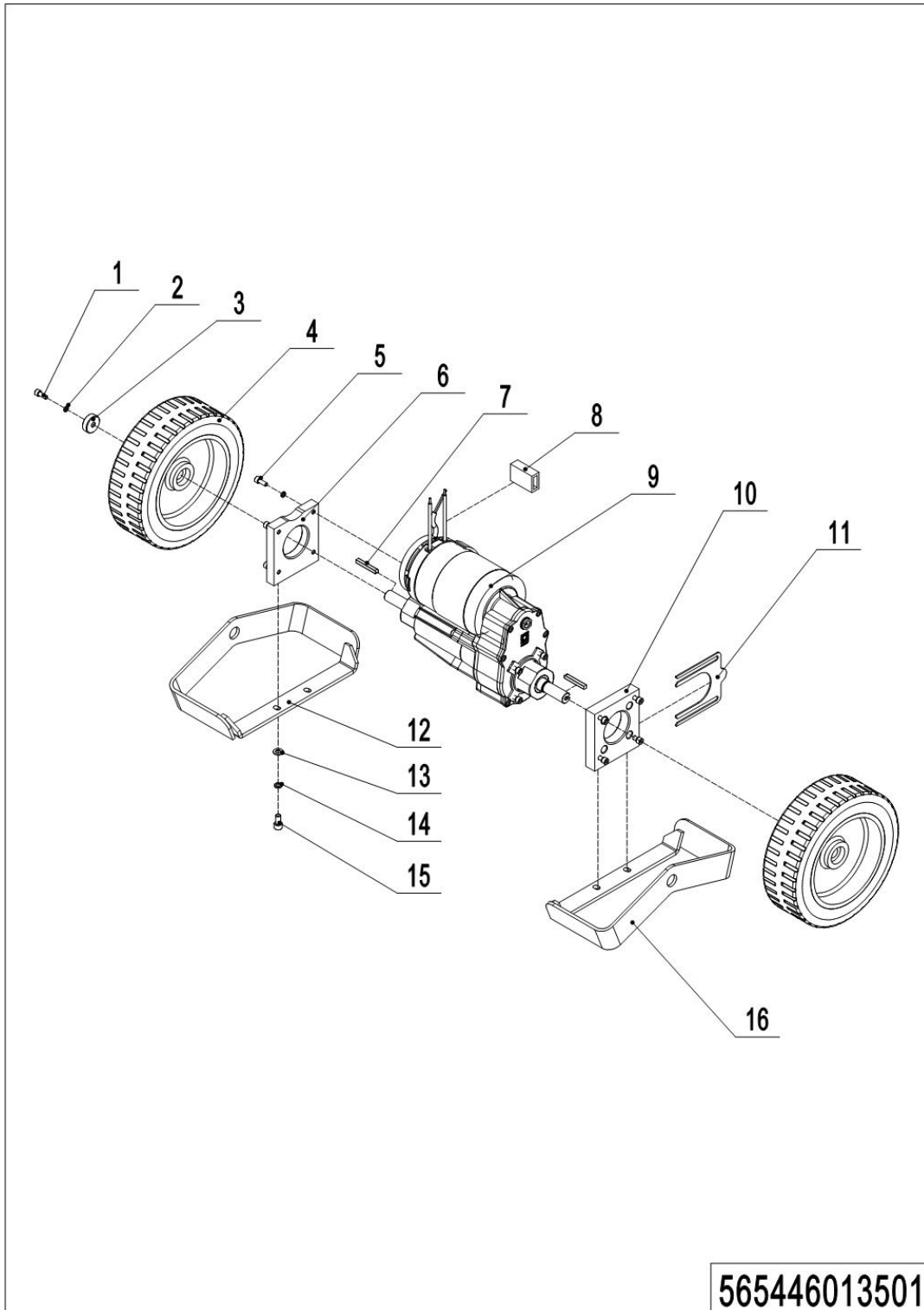

01 Drive Assembly (565446013501)

No.	Item Code	Mark	Item Description	Qty.	Substitute	Note
1	910200200035	1	Screw	2		
2	910400500005	1	Spring Washer	14		
3	565313520000	2	Retaining Ring	2		
4	940300400001	2	Wheel Φ 250x80	2		
5	910200200036	1	Screw	12		
6	565313520002	2	Mounting Plate	1		
7	910600800017	1	Flat Key	2		
8	921500100195	2	Magnetic Ring	1		
9	-----	5	Drive Unit	1		Check 565346013502
10	565313520001	2	Mounting Plate	1		
11	565313520003	2	Subplate	1		Quantity optional
12	565413510001	2	Protective Cover	1		
13	910400100006	1	Flat Washer	4		
14	910400500006	1	Spring Washer	4		
15	910200200055	1	Screw	4		
16	565413510000	2	Protective Cover	1		

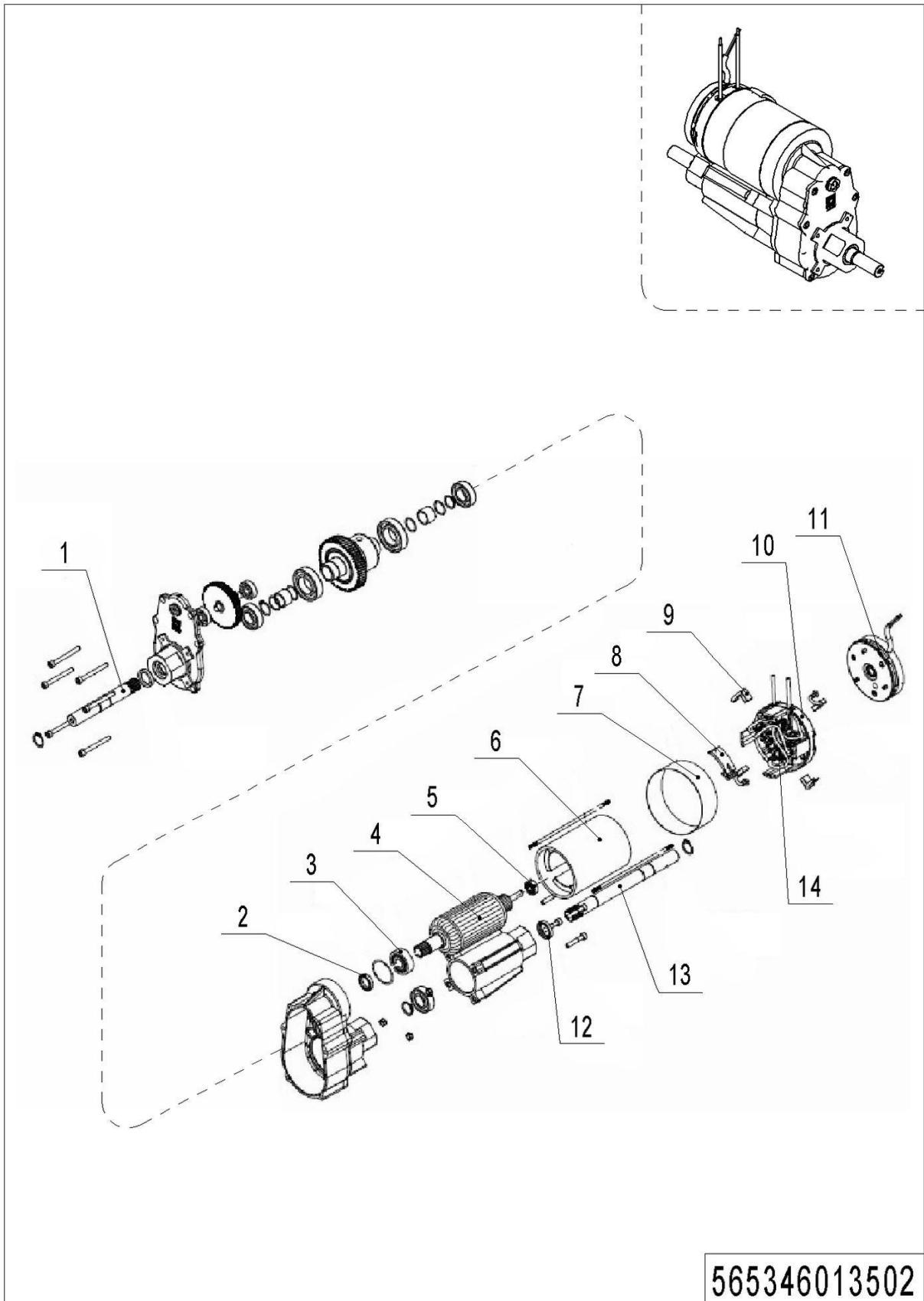
02 Drive Unit (565346013502)

1= Supply as package. 2= Supply with constraints. 3= Phasing-out supply. 4= Supply as assembly. 5= Check other tables.

02 Drive Unit (565346013502)

No.	Item Code	Mark	Item Description	Qty.	Substitute	Note
--	565313520007	2	Drive motor	1		
1	565398520012	2	Axle	1		
2	565398520001	2	Sealing Ring	1		
3	565398520006	2	Bearing	1		
4	565398520005	2	Armature	1		
5	565398520003	2	Bearing	1		
6	565398520004	2	Stator	1		
7	565398520009	2	Brush Cover	1		
8	565398520002	2	Safety Hook	1		
9	565398520007	2	Brush	4		
10	565398520008	2	Brush Cover	1		
11	502398510005	2	Brake	1		
12	565398520011	2	Sealing Ring	2		
13	565398520010	2	Axle	1		
14	565398520013	2	Pedestal	1		

Chapter 2: Truck Frame

01 Traction Frame Unit (565446038001)

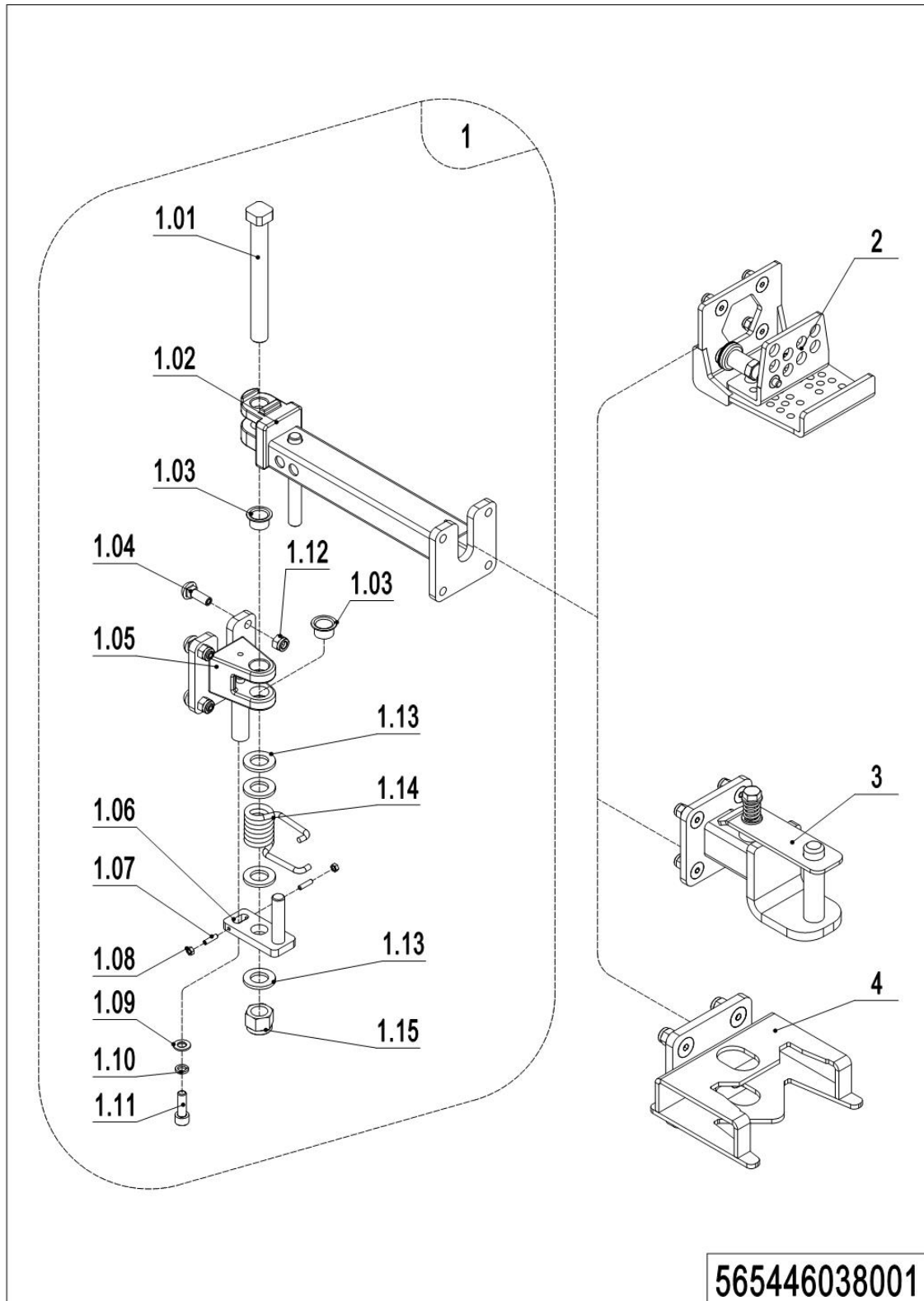

01 Traction Frame Unit (565446038001)

No.	Item Code	Mark	Item Description	Qty.	Substitute	Note
1	565438010008	2	Traction kit	1		
1.01	565438020008	2	Bolt	1		
1.02	565438010001	2	Traction Rod	1		
1.03	940500200018	2	Bushing	2		
1.04	910101500002	1	Bolt	4	910101300004	
1.05	565438010000	2	Fixing Base	1		
1.06	565438010006	2	Bracket	1		
1.07	910200800046	1	Screw	2		
1.08	910300100003	1	Nut	2		
1.09	910400100006	1	Flat Washer	1		
1.10	910400500006	1	Spring Washer	1		
1.11	910200200058	1	Screw	1		
1.12	910300500004	1	Nut	4		
1.13	910400100010	1	Flat Washer	4		
1.14	565438020028	2	Torsional Spring	1		
1.15	910300500008	1	Nut	1		
2	565438010007	2	Traction Frame Kit(S)	1		
3	565438010010	2	Traction Frame Kit(P)	1		
4	565438010014	2	Traction Frame Kit(LKE)	1		

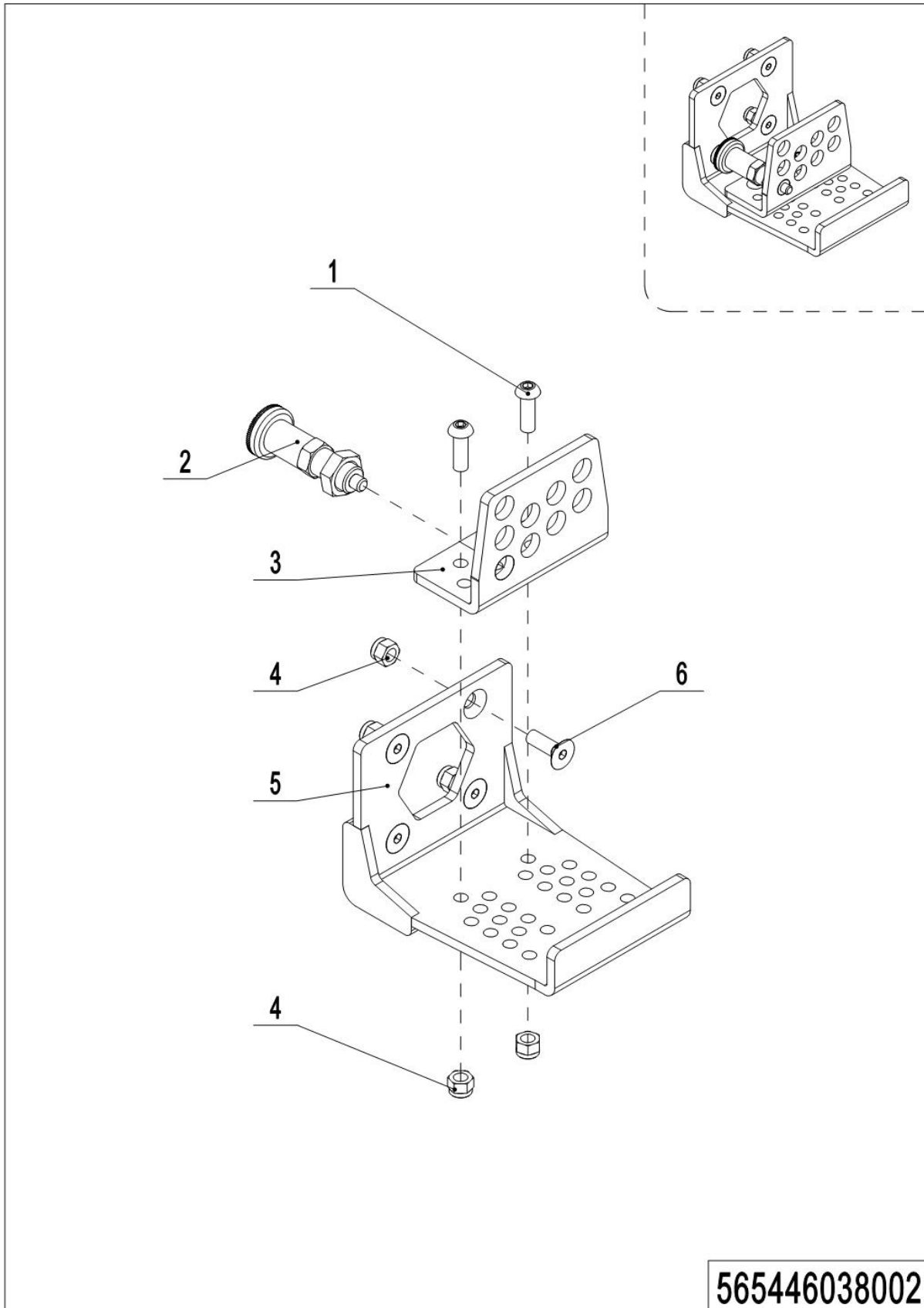
02 Traction Frame (S) (565446038002)

1= Supply as package. 2= Supply with constraints. 3= Phasing-out supply. 4= Supply as assembly. 5= Check other tables.

02 Traction Frame (S) (565446038002)

No.	Item Code	Mark	Item Description	Qty.	Substitute	Note
--	565438010007	2	Traction Frame Kit(S)	1		
1	910200300025	1	Screw	2		
2	940800900004	2	Indexing Plunger	1		
3	565438020006	2	Plate	1		
4	910300500004	1	Nut	6		
5	565438010016	2	Plate	1		
6	910200400026	1	Screw	4		

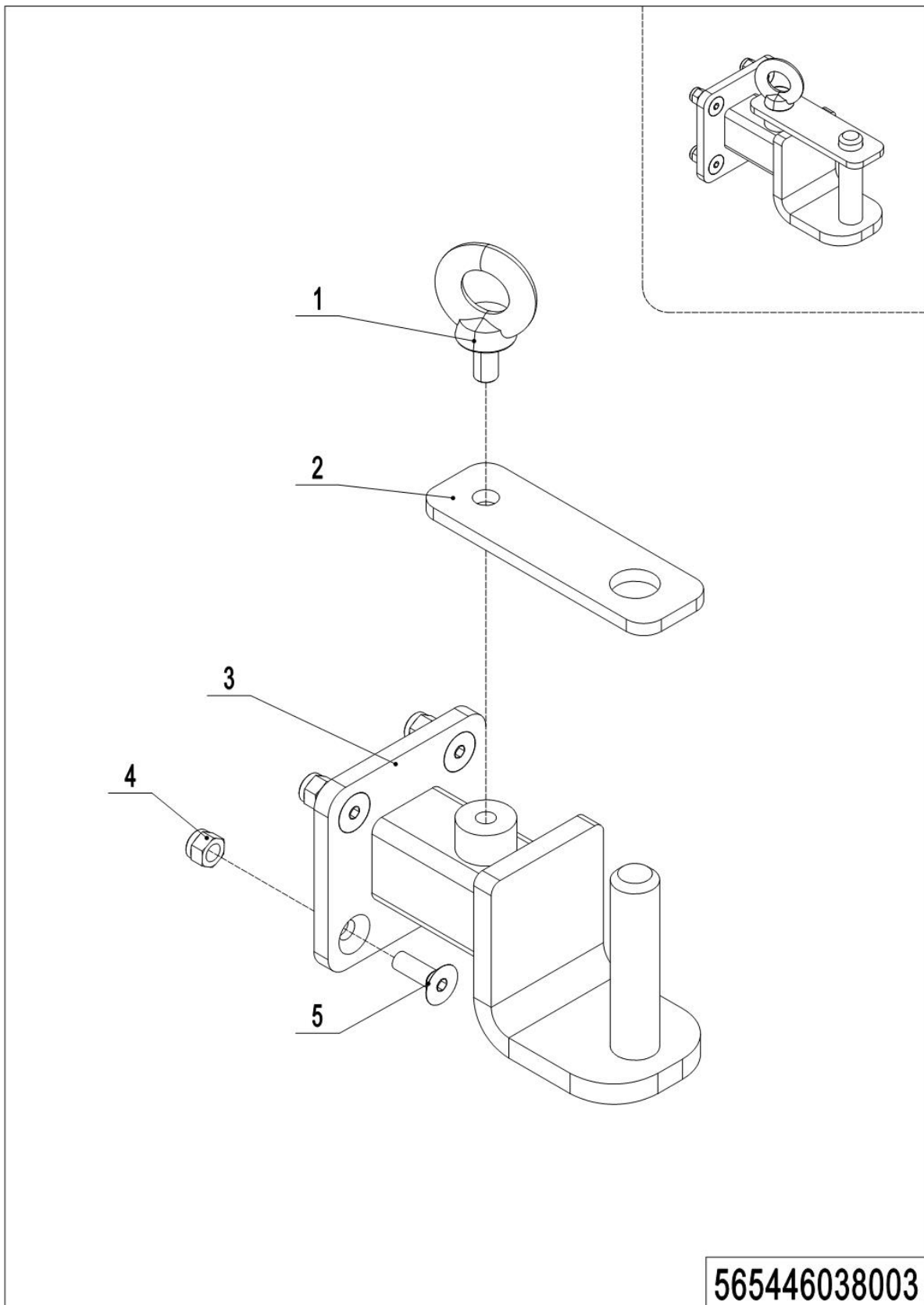
03 Traction Frame (P) (565446038003)

03 Traction Frame (P) (565446038003)

No.	Item Code	Mark	Item Description	Qty.	Substitute	Note
--	565438010010	2	Traction Frame Kit(P)	1		
1	910201700004	1	Screw	1		
2	565438020014	2	Fixing Plate	1		
3	565438010003	2	Mounting base	1		
4	910300500004	1	Nut	4		
5	910200400026	1	Screw	4		

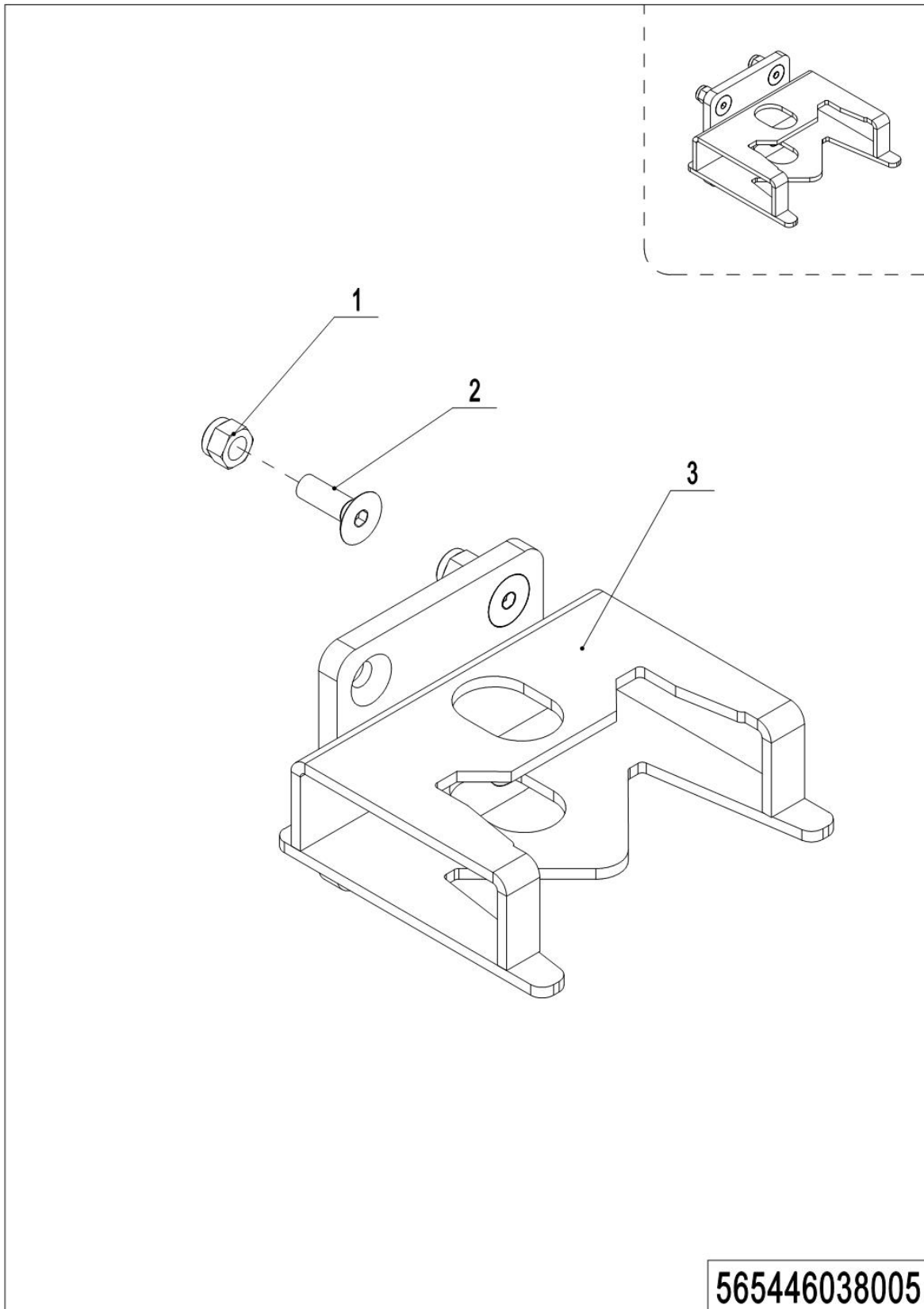
04 Traction Frame (LKE) (565446038005)

04 Traction Frame (LKE) (565446038005)

No.	Item Code	Mark	Item Description	Qty.	Substitute	Note
--	565438010014	2	Traction Frame Kit (LKE)	1		
1	910300500004	1	Nut	4		
2	910200400026	1	Screw	4		
3	565438010013	2	Traction Frame (LKE)	1		

05 Chassis (565446021501)

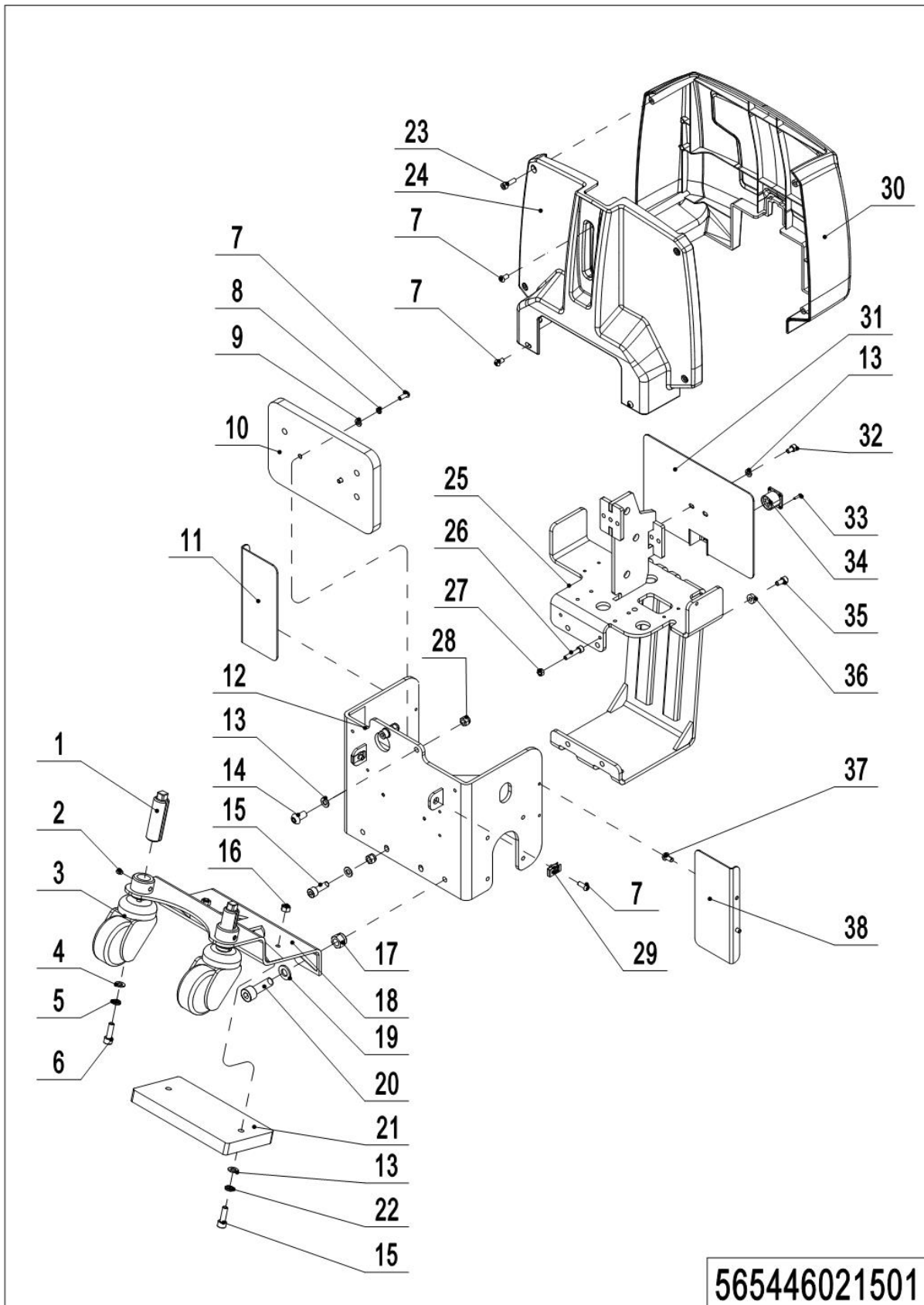

05 Chassis (565446021501)

No.	Item Code	Mark	Item Description	Qty.	Substitute	Note
1	565321520014	2	Screw	2		
2	910201000009	1	Screw	2		
3	940300601033	2	Caster	2		
4	910400100007	1	Flat Washer	2		
5	910400500007	1	Spring Washer	2		
6	910200200076	1	Screw	2		
7	910200300018	1	Screw	8		
8	910400500005	1	Spring Washer	2		
9	910400100005	1	Flat Washer	2		
10	565421520014	2	Balance Weight	1		
11	565421520017	2	Baffle	1		
12	565421510001	2	Chassis	1		
13	910400100006	1	Flat Washer	8		
14	910200300026	1	Screw	2		
15	910200200058	1	Screw	4		
16	910300100006	1	Nut	2		
17	910300500006	1	Nut	2		
18	565321510002	2	Bracket	1		
19	910400100008	1	Flat Washer	2		
20	910200200098	1	Screw	2		
21	565421520013	2	Balance Weight	1		
22	910400500006	1	Spring Washer	2		
23	910200200036	1	Screw	4		
24	565421520016	2	Cover	1		
25	565421510002	2	Bracket	1		
26	910200200039	1	Screw	2		
27	910300100005	1	Nut	2		
28	910300500004	1	Nut	4		
29	940400400001	2	Cage Nut	2		
30	565421520015	2	Cover	1		

05 Chassis (565446021501) Continuation

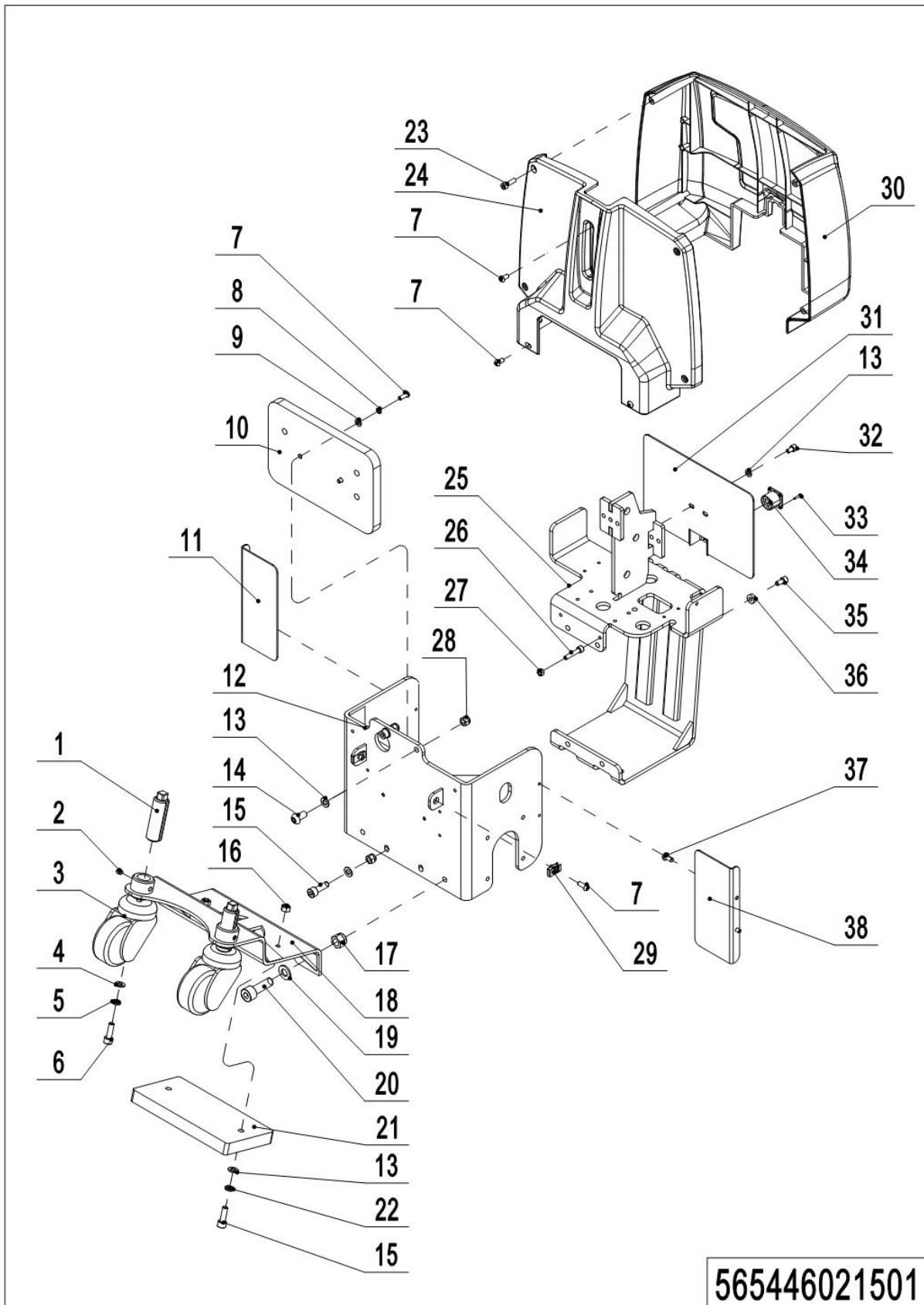

1= Supply as package. 2= Supply with constraints. 3= Phasing-out supply. 4= Supply as assembly. 5= Check other tables.

05 Chassis (565446021501) Continuation

No.	Item Code	Mark	Item Description	Qty.	Substitute	Note
31	565421510004	2	Bumper Rail	1		
32	910200200051	1	Screw	2		
33	910200600001	1	Screw	4		
34	921500100129	2	Cable	1		
35	910200200055	1	Screw	1		
36	940600500001	1	Washer	1		
37	910200300011	1	Screw	4		
38	565421520012	2	Baffle	1		

Chapter 3: Steering System, Braking System, Wheels

01 Tiller Unit (565446011001)

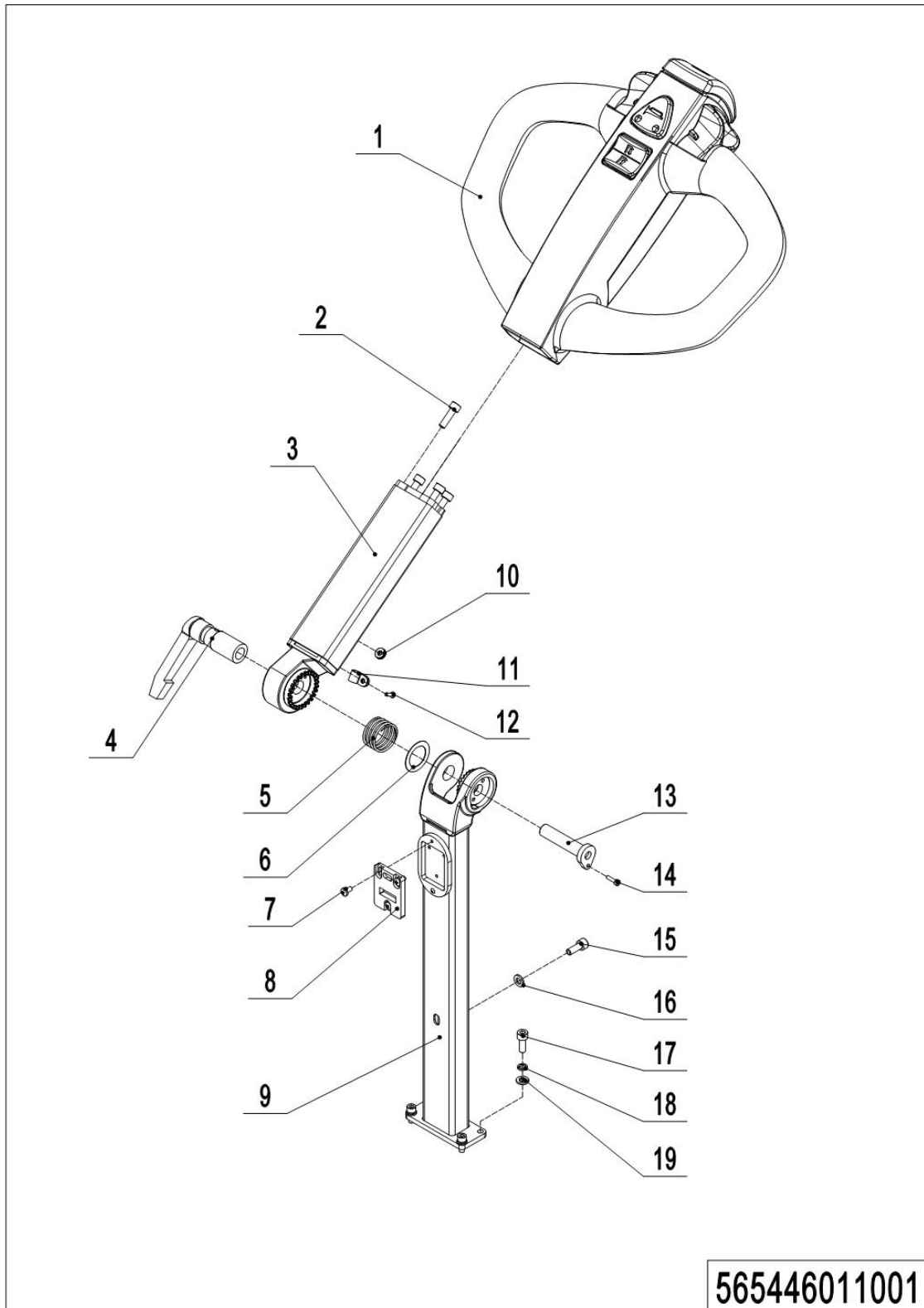

01 Tiller Unit (565446011001)

No.	Item Code	Mark	Item Description	Qty.	Substitute	Note
1	922100100096	2	Control Handle	1		
2	910200200036	1	Screw	4		
3	565411010002	2	Tiller	1		
4	565411010004	2	Adjustable handle	1		
5	565411020015	2	Spring	1		
6	565411020014	2	Washer	1		
7	910200500034	1	Screw	3		
8	508038520109	2	Lock	1		
9	565498510005	2	Rod	1		
10	502311020009	1	Close Plate	1		
11	921300200001	2	Cable Clamp	1		
12	910200300005	1	Screw	1		
13	565411010003	2	Axle	1		
14	910200200021	1	Screw	1		
15	910200200055	1	Screw	1		
16	910400100006	1	Flat Washer	1		
17	910200200035	1	Screw	4		
18	910400500005	1	Spring Washer	4		
19	910400100005	1	Flat Washer	4		

02 Control Handle (565446011002)

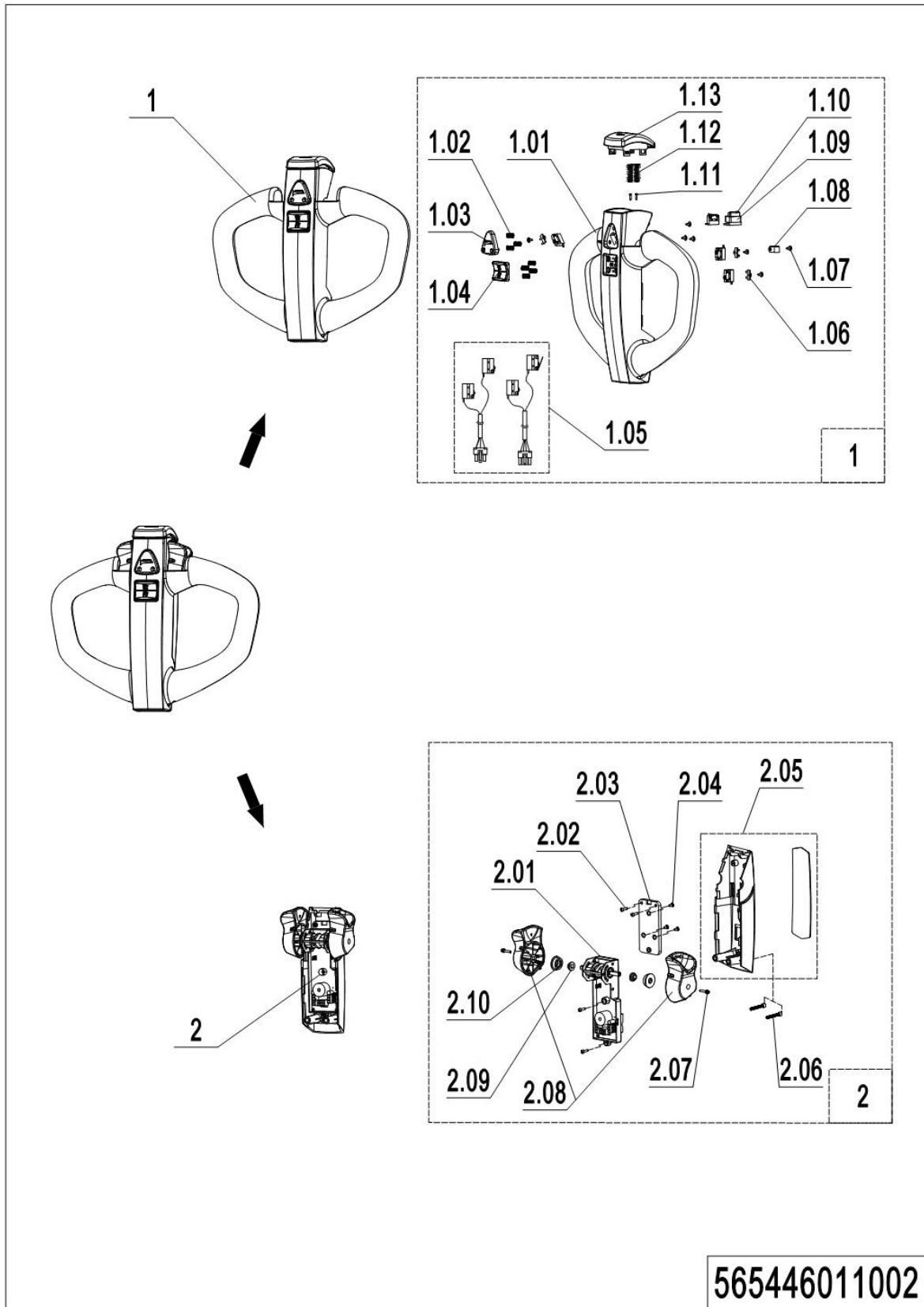

1= Supply as package. 2= Supply with constraints. 3= Phasing-out supply. 4= Supply as assembly. 5= Check other tables.

02 Control Handle (565446011002)

No.	Item Code	Mark	Item Description	Qty.	Substitute	Note
1	565498510003	2	Handle Cap Kit	1		
1.01	565498520003	2	Handle Cap	1		
1.02	509998520037	2	Spring	7		
1.03	509998520039	2	Button Cap	1		
1.04	509998520038	2	Button Cap	1		
1.05	565498510004	2	Microswitch Kits	1		
1.06	509998520045	2	Locating Plate	3		
1.07	910200600002	1	Screw	7		
1.08	509998520044	2	Cable Clip	1		
1.09	565498520000	2	Fixing Mount	1		
1.10	565498520001	2	Hoop	1		
1.11	910201400001	1	Screw	2		
1.12	509998520041	2	Spring	1		
1.13	509998520040	2	Switch	1		
2	565498510001	2	Handle Cap Kit	1		
2.01	565498520002		Accelerator	1		
2.02	910200400004	1	Screw	4		
2.03	509998520047		Fixing Plate	1		
2.04	910200500019	1	Screw	3		
2.05	565498510002		Handle Cap Kit	1		
2.06	910200200030	1	Screw	2		
2.07	910200200004	1	Screw	2		
2.08	509998510022	2	Traction lever	1		
2.09	509998520049	2	Sleeve	2		
2.10	509998520050	2	Spacer Bush	2		

Chapter 4: Electrical Parts

01 Wire Harness (565446033001)

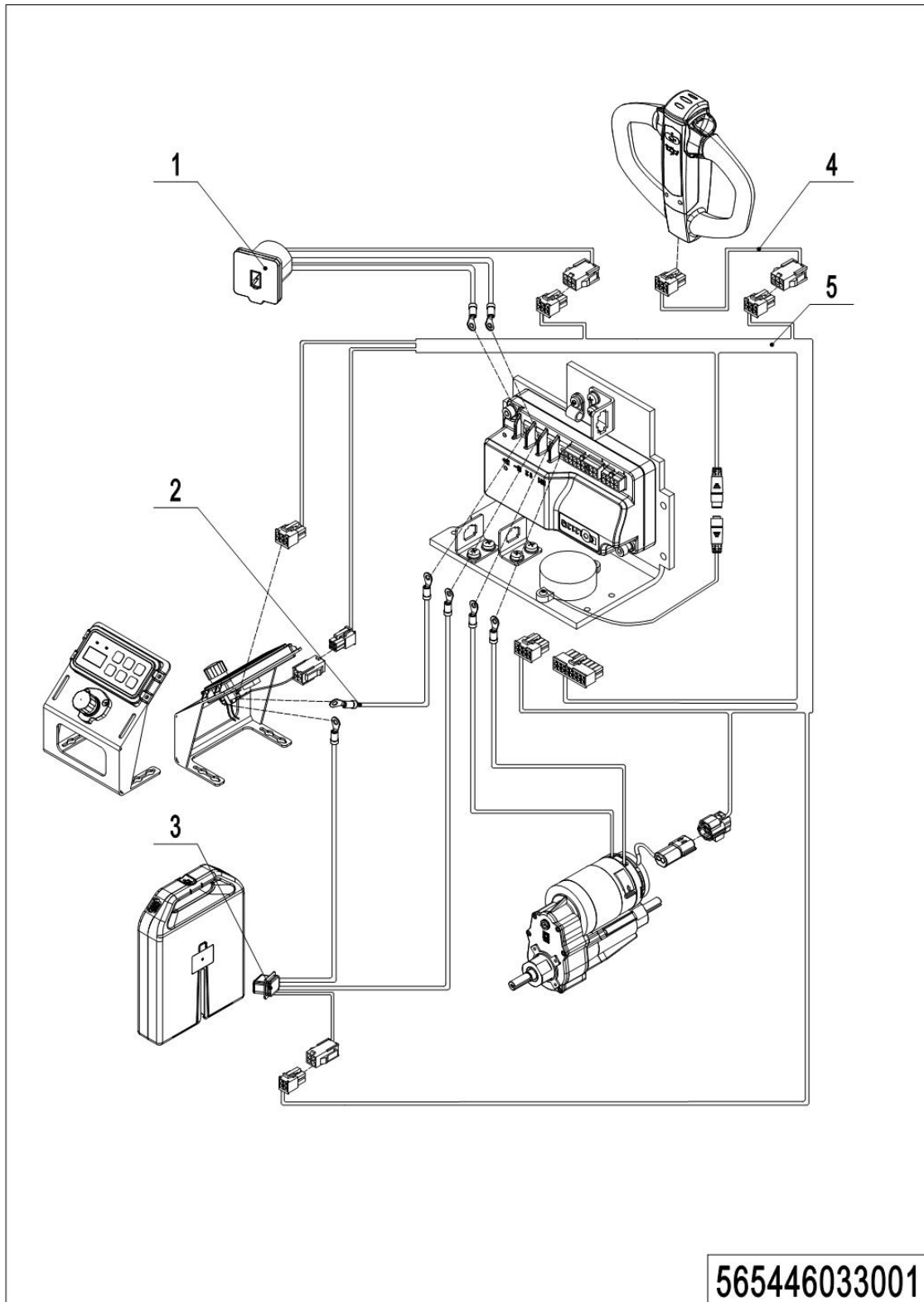

01 Wire Harness (565446033001)

No.	Item Code	Mark	Item Description	Qty.	Substitute	Note
1	565433010008	2	Wire Harness	1		
2	565433010001	2	Wire Harness	1		
3	565433010002	2	Wire Harness	1		
4	565433010003	2	Wire Harness	1		
5	565433010004	2	Wire Harness	1		

02 Electronic Components (565446033002)

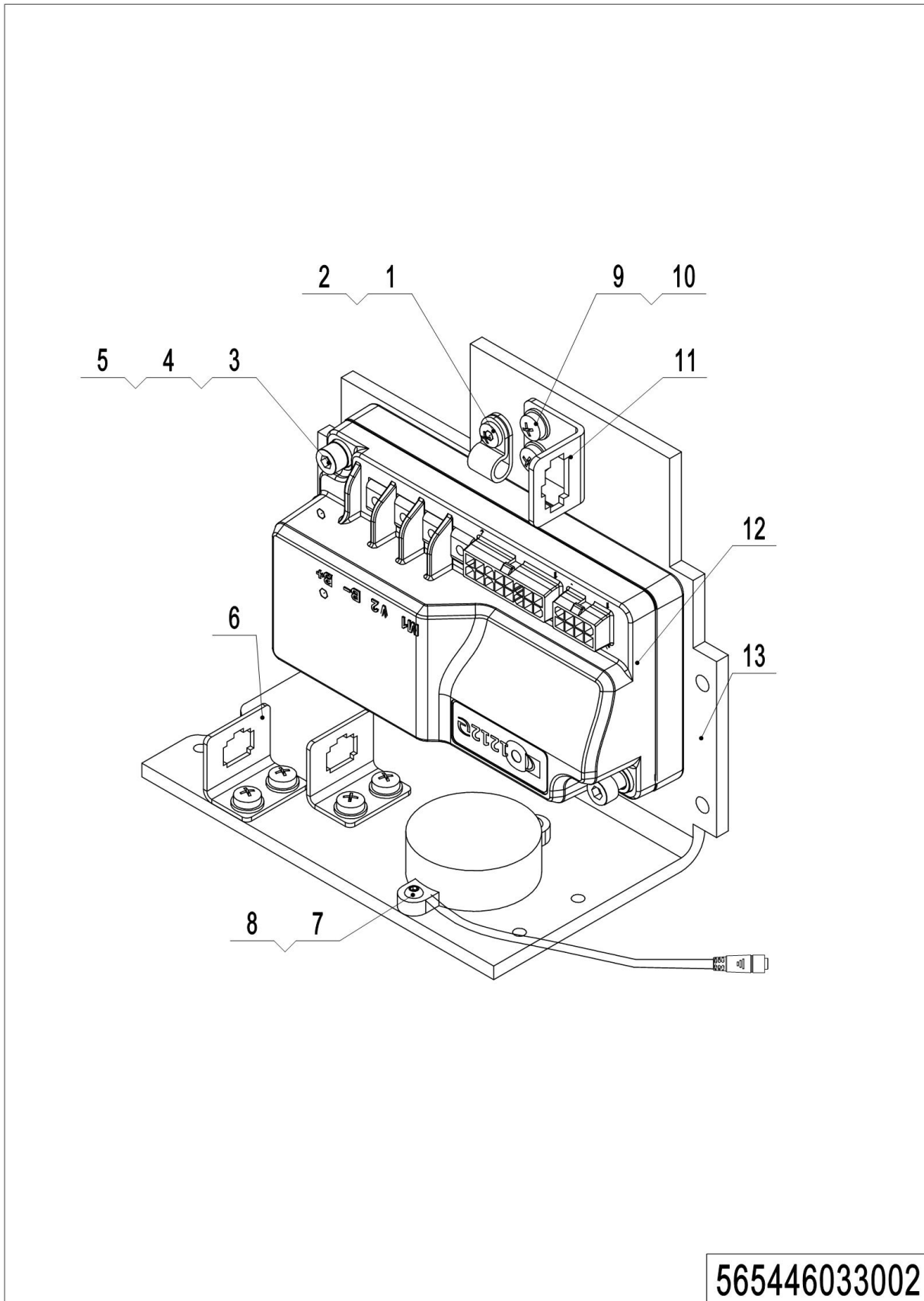

565446033002

1= Supply as package. 2= Supply with constraints. 3= Phasing-out supply. 4= Supply as assembly. 5= Check other tables.

02 Electronic Components (565446033002)

No.	Item Code	Mark	Item Description	Qty.	Substitute	Note
1	910200500034	1	Screw	3		
2	921300200002	2	Cable Clamp	3		
3	910200200025	1	Screw	2		
4	910400500017	1	Spring Washer	2		
5	910400100004	1	Flat Washer	2		
6	565433020004	2	Fixing Mount	2		
7	920500100013	2	Buzzer	1		
8	910200300002	1	Screw	2		
9	910200500039	1	Screw	6		
10	910400500017	1	Spring Washer	6		
11	921300300023	2	Fixing Mount	1		
12	921400100174	2	Controller	1		1212E-2503
12	921400100081	2	Controller	1		1212C-2503
13	565433020000	2	Mounting Plate	1		

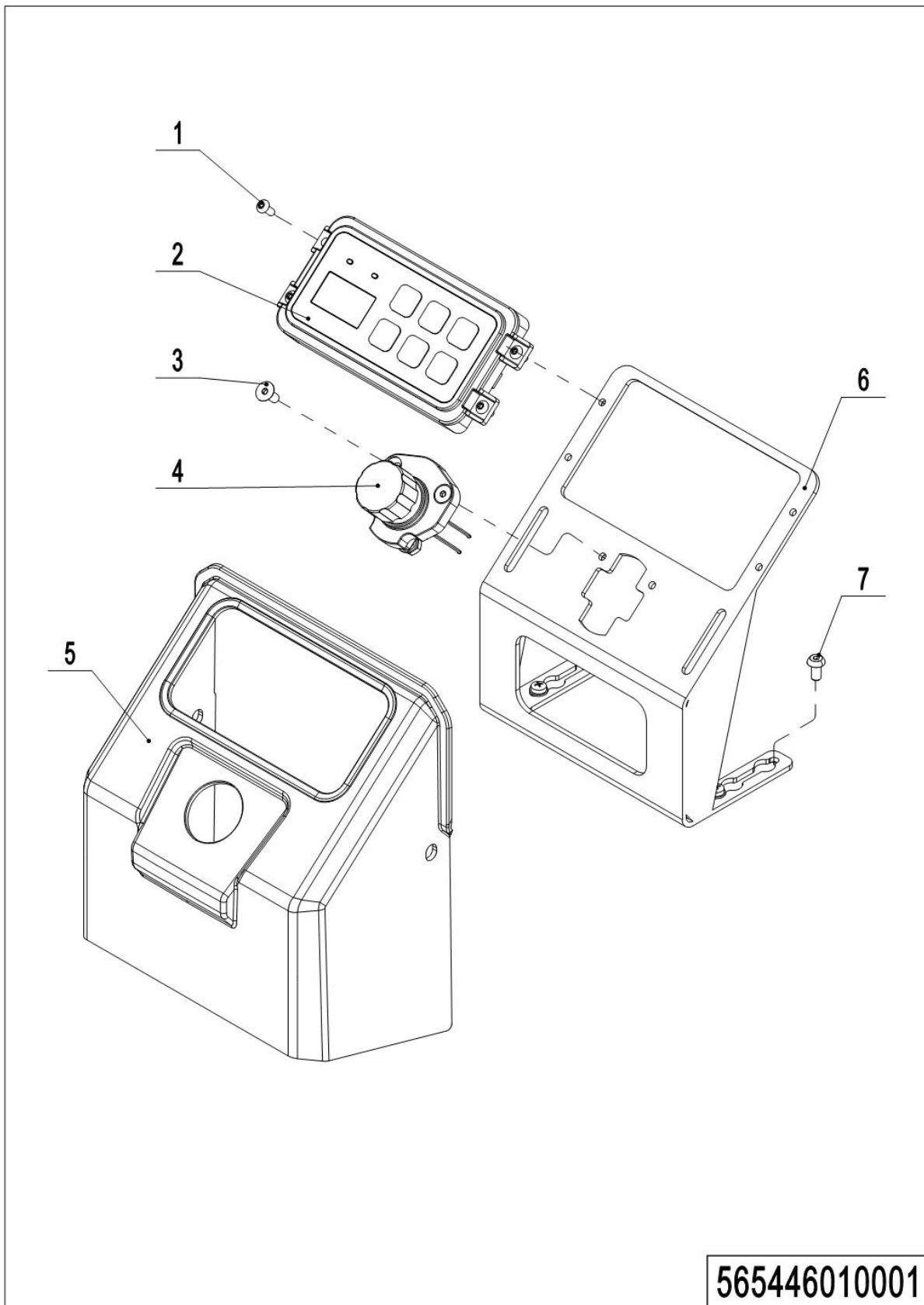
03 Display Assembly (565446010001)

1= Supply as package. 2= Supply with constraints. 3= Phasing-out supply. 4= Supply as assembly. 5= Check other tables.

03 Display Assembly (565446010001)

No.	Item Code	Mark	Item Description	Qty.	Substitute	Note
1	910200300006	1	Screw	4		
2	920200200030	2	Pin-code Lock	1		
3	910200400010	1	Screw	2		
4	920200100027	2	Emergency Button	1		
5	565433020003	2	Cover	1		
6	565433010000	2	Mounting Plate	1		
7	910200300011	1	Screw	4		

04 Charger (508046036501)

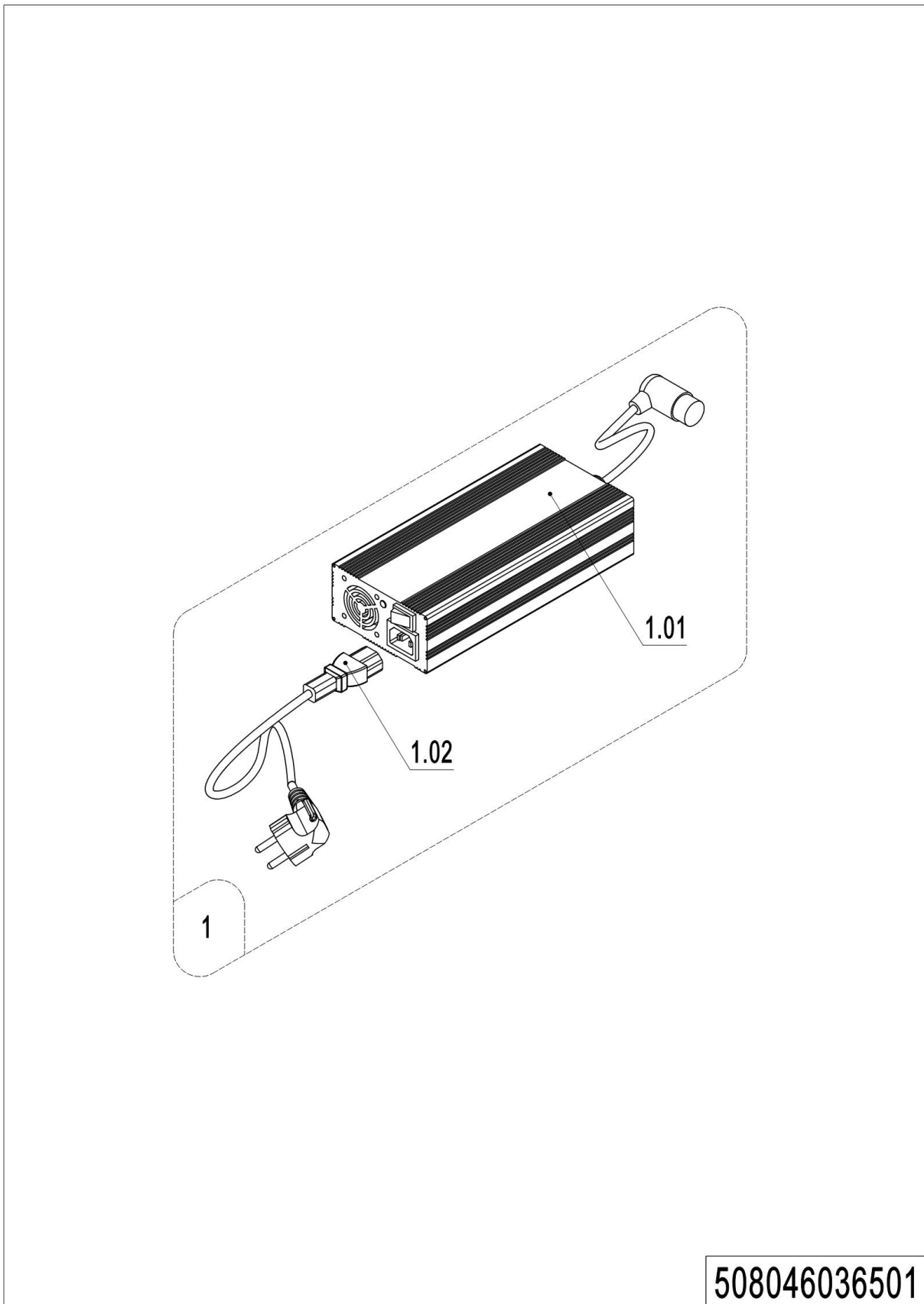

1= Supply as package. 2= Supply with constraints. 3= Phasing-out supply. 4= Supply as assembly. 5= Check other tables.

04 Charger (508046036501)

No.	Item Code	Mark	Item Description	Qty.	Substitute	Note
1	921000200464	2	Charger 24V8A (Aisa-ENG)	1		SS
1	508036510002	2	Charger24V8A (ENG)	1		SS
1	508036510004	2	Charger24V8A (EU)	1		SS
1	508036510005	2	Charger24V8A (AUS)	1		SS
1	508036510006	2	Charger24V8A (ITA)	1		SS
1	508036510007	2	Charger24V8A (SWE)	1		SS
1	508036510008	2	Charger24V8A (ISR)	1		SS
1	508036510009	2	Charger24V8A (BRA)	1		SS
1	508036510010	2	Charger24V8A (ARG)	1		SS
1	508036510039	2	Charger24V8A (EU, Aisa)	1		SS
1	508036510054	2	charger24V12A (ENG)	1		WT
1	508036510055	2	charger24V12A (US)	1		WT
1	508036510056	2	charger24V12A (EU)	1		WT
1	508036510057	2	charger24V12A (AUS)	1		WT
1	508036510058	2	charger24V12A (ITA)	1		WT
1	508036510059	2	charger24V12A (SWE)	1		WT
1	508036510060	2	charger24V12A (ISR)	1		WT
1	508036510061	2	charger24V12A (BRA)	1		WT
1	508036510062	2	charger24V12A (ARG)	1		WT
1	508036510063	2	charger24V12A (ZA)	1		WT
1	508036510064	2	charger24V12A (IND)	1		WT
1	921000200577	2	charger24V12A (JPN)	1		QQE
1.01	921000200464	2	Charger 24V8A (Aisa-ENG)	1		SS
1.01	921000200355	2	Charger 24V8A	1		SS (CE)
1.02	921500200050	2	Power Cord (ARG)	1		
1.02	921500200024	2	Power Cord (AUS)	1		
1.02	921500200049	2	Power Cord (BRA)	1		
1.02	921500200022	2	Power Cord (EU)	1		
1.02	921500200026	2	Power Cord (SWE)	1		
1.02	921500200028	2	Power Cord (ISR)	1		

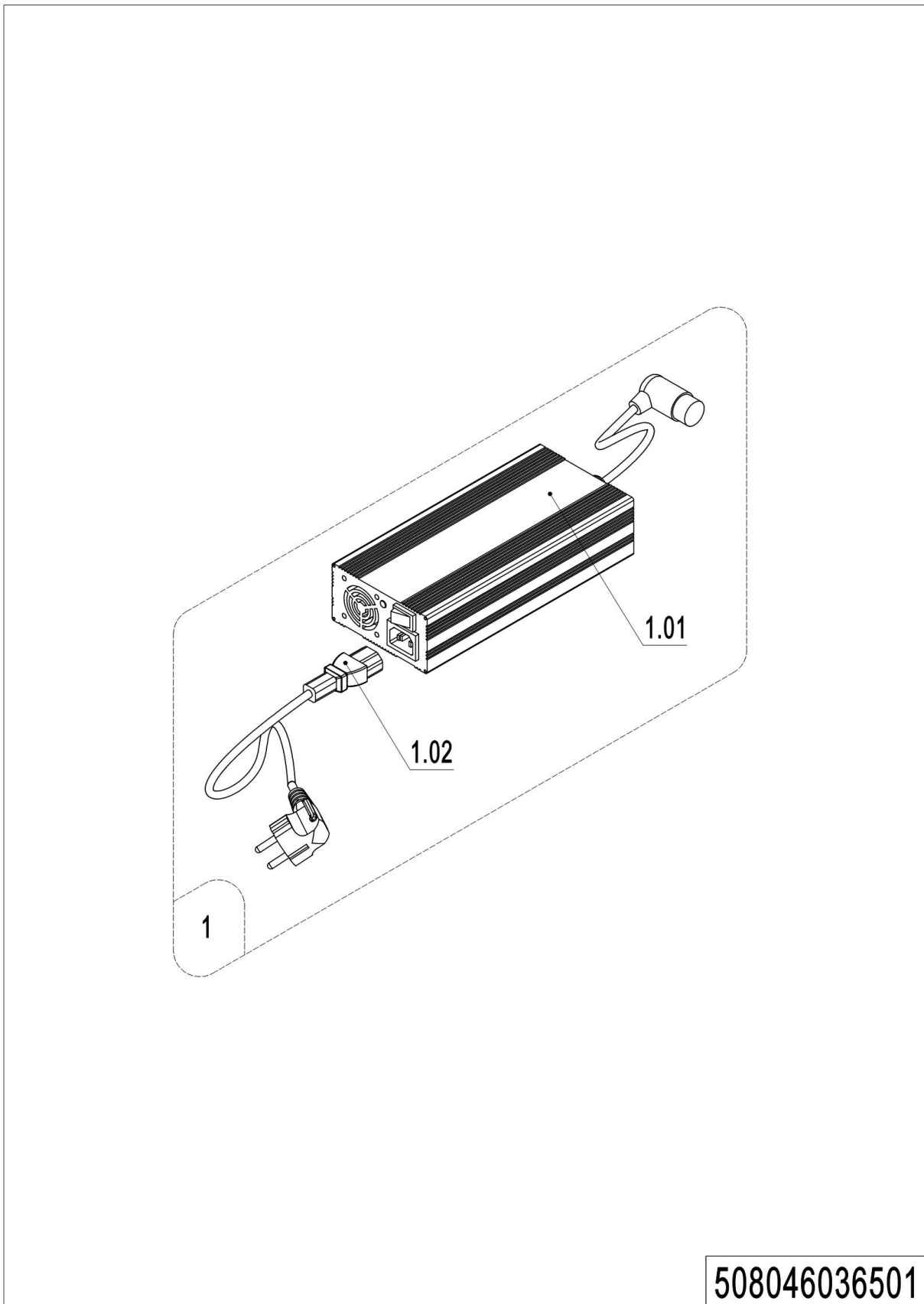
04 Charger (508046036501) Continuation

04 Charger (508046036501) Continuation

No.	Item Code	Mark	Item Description	Qty.	Substitute	Note
1.02	921500200025	2	Power Cord(ITA)	1		
1.02	921500200021	2	Power Cord (Asia)	1		
1.02	921500200027	2	Power Cord(ENG)	1		
1.02	921500200023	2	Power Cord(USA)	1		
1.02	921500200063	2	Power Cord(ZA)	1		
1.02	921500200047	2	Power Cord(ENG)	1		

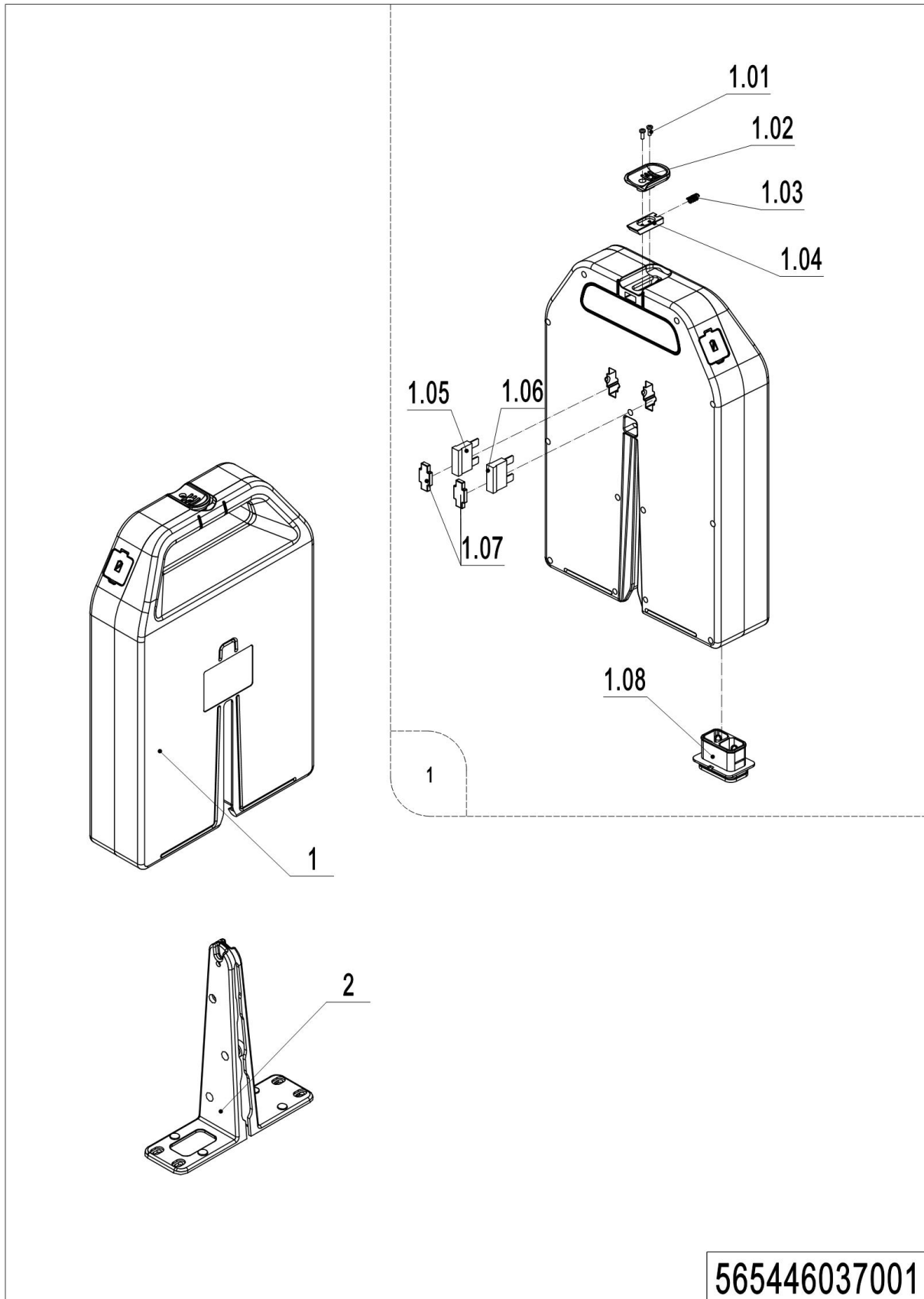
05 Traction Battery (565446037001)

05 Traction Battery (565446037001)

No.	Item Code	Mark	Item Description	Qty.	Substitute	Note
1	508037010033	2	Li Battery24V36Ah	1		
1.01	910200500011	2	Screw	2		
1.02	508098520022	2	Plastic Handle	1		
1.03	508098520024	2	Spring	1		
1.04	508098520023	2	Fixing Mount	1		
1.05	920100200006	2	Fuse	1		
1.06	508098520050	2	Fuse	1		
1.07	508098520021	2	waterproof plug	1		
1.08	508098510069	2	Rubber Cover	1		
2	508033010020	2	Battery Rack	1		

Chapter 5: Others

01 Label and Decal (565446047001)

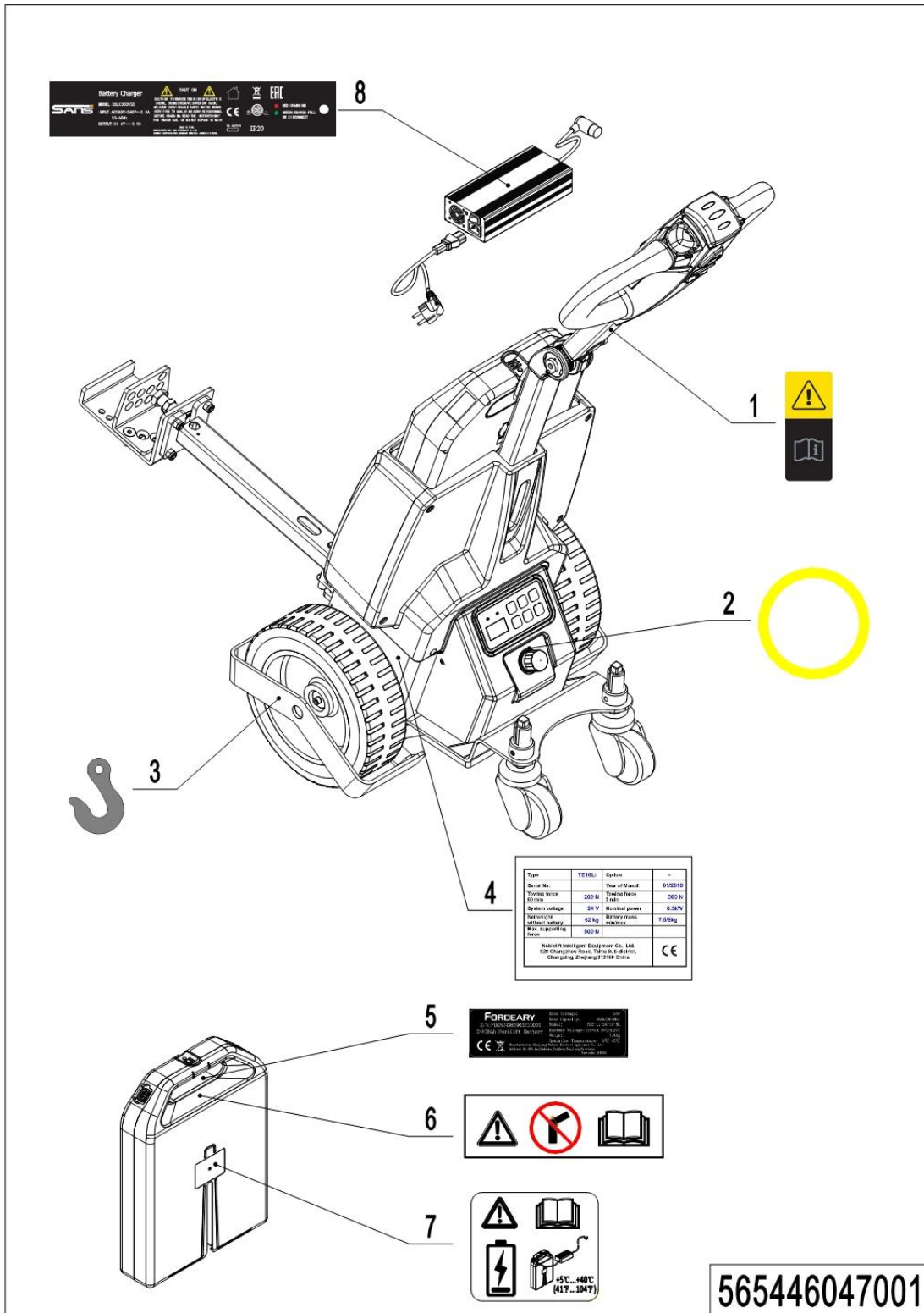

1= Supply as package. 2= Supply with constraints. 3= Phasing-out supply. 4= Supply as assembly. 5= Check other tables.

01 Label and Decal (565446047001)

No.	Item Code	Mark	Item Description	Qty.	Substitute	Note
1	508047520014	2	Label	1		
2	941200400014	2	Label	1		
3	941200300001	2	Label	2		
4	565447520000	2	Truck data plate	1		
5	508047020009	2	Label	1		
6	508047020002	2	Label	1		
7	508098520025	2	Label	1		
8	508047520005	2	Label	1		

02 Label and Decal (USA) (565446047004)

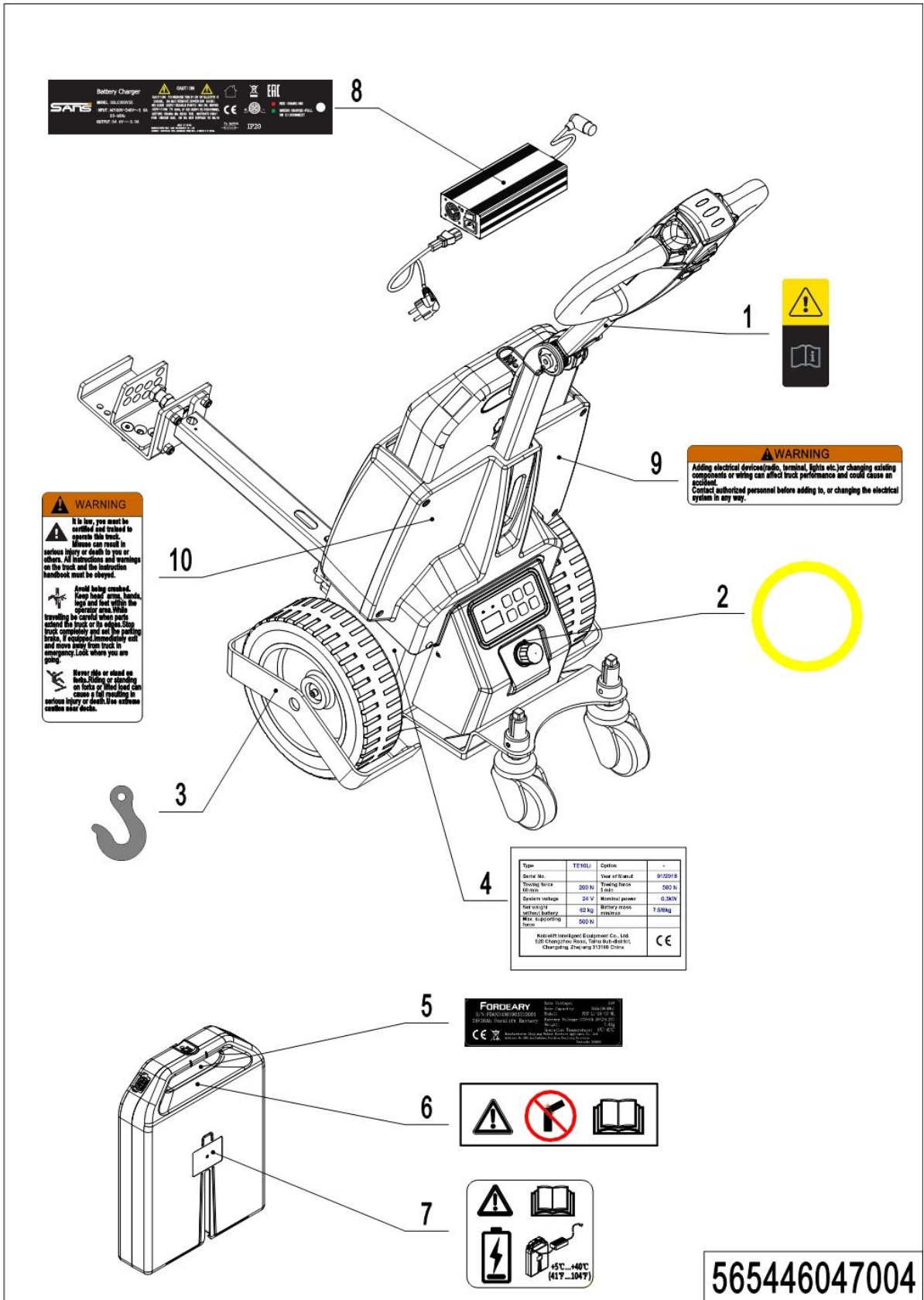

1= Supply as package. 2= Supply with constraints. 3= Phasing-out supply. 4= Supply as assembly. 5= Check other tables.

02 Label and Decal (USA) (565446047004)

No.	Item Code	Mark	Item Description	Qty.	Substitute	Note
1	508047520014	2	Label	1		
2	941200400014	2	Label	1		
3	941200300001	2	Label	2		
4	565447520001	2	Truck data plate	1		
5	508047020009	2	Label	1		
6	508047020002	2	Label	1		
7	508098520025	2	Label	1		
8	508047520005	2	Label	1		
9	941200100010	2	Label	1		
10	941200100009	2	Label	1		

Appendix

01 Electrical Circuit Diagram

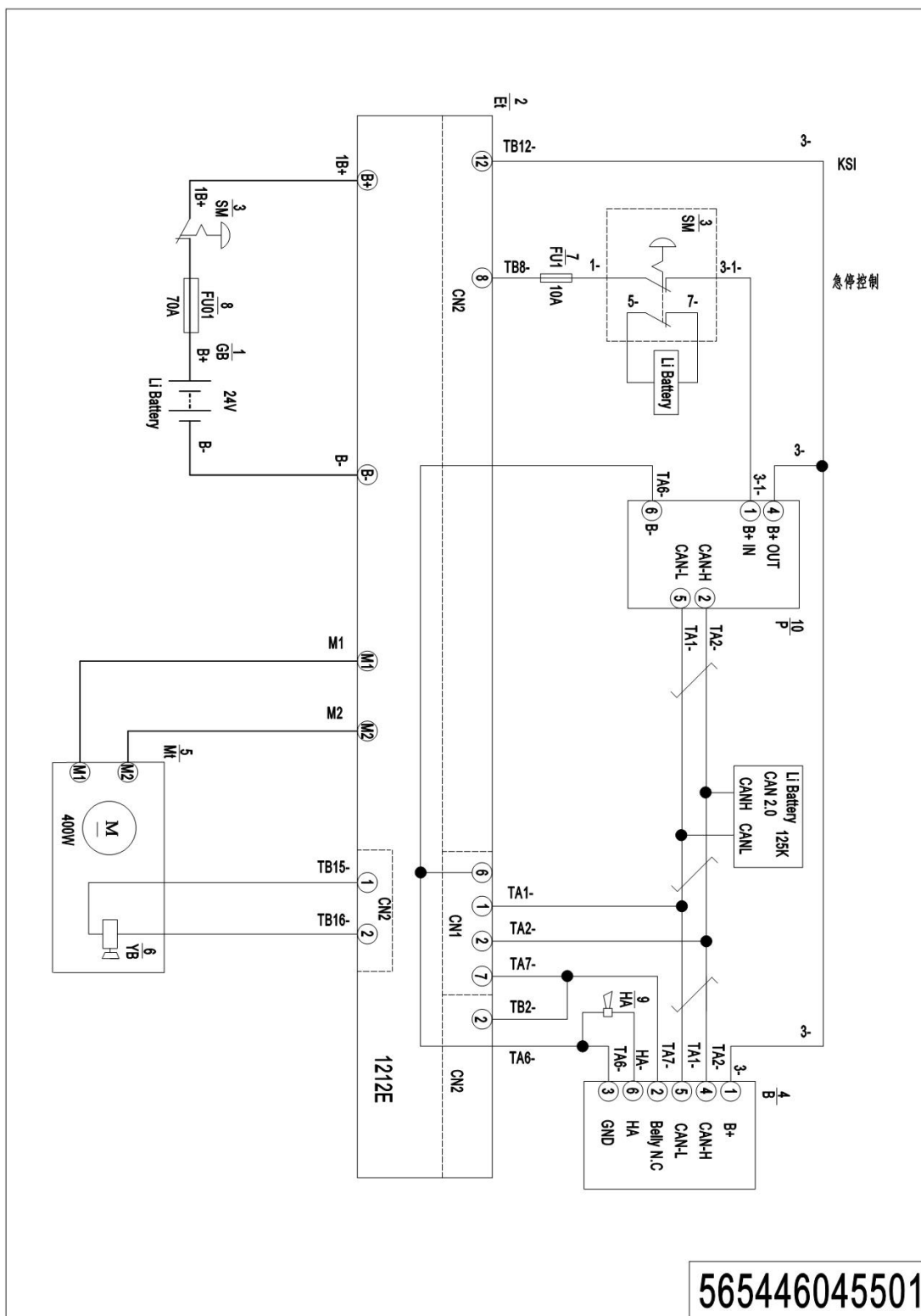

1= Supply as package. 2= Supply with constraints. 3= Phasing-out supply. 4= Supply as assembly. 5= Check other tables.

02 Consumable Parts List

No.	Item Code	Item Description	Qty.	Chapter/ Section/ Number
1	940300601033	Caster	2	Chapter 2/05/3
2	940300400001	Wheel Φ 250x80	2	Chapter 1/01/4
3	565498520002	Accelerator	1	Chapter 3/02/2. 01
4	565498510004	Microswitch Kits	1	Chapter 3/02/1. 05
5	920200100027	Emergency Button	1	Chapter 4/03/4
6	920100200006	Fuse	1	Chapter 4/05/1. 05
7	508098520050	Fuse	1	Chapter 4/05/1. 06